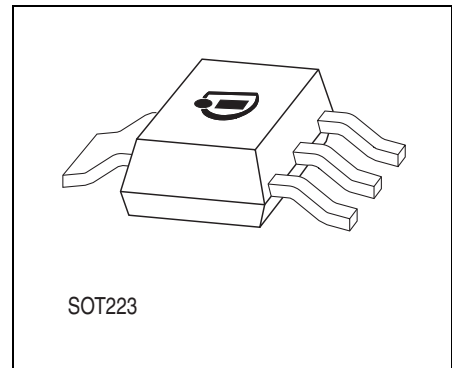


## Features

- Output voltage 5 V or 10 V
- Output voltage tolerance  $\leq \pm 2\%$
- 120 mA current capability
- Very low current consumption
- Low-drop voltage
- Overtemperature protection
- Reverse polarity proof
- Wide temperature range
- Suitable for use in automotive electronics
- Inhibit



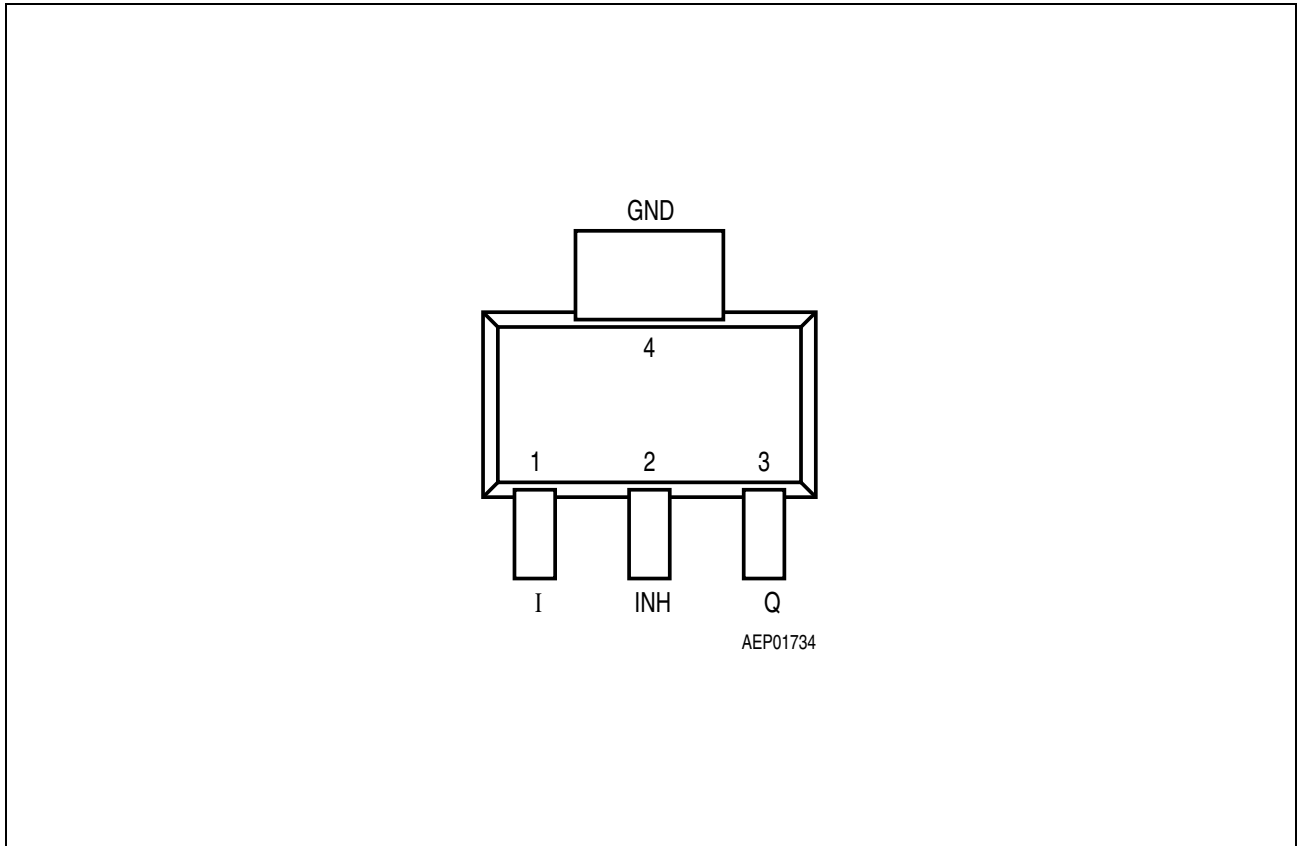
## Functional Description

TLE 4266 is a low-drop voltage regulator for 5 V or 10 V supply in a P-SOT223-4-2 SMD package. The IC regulates an input voltage  $V_I$  in the range of 5.5 V/10.5 V  $< V_I < 45$  V to  $V_{Q,nom} = 5$  V/10 V. The maximum output current is more than 120 mA. The IC can be switched off via the inhibit input, which causes the current consumption to drop below 10  $\mu$ A. The IC is shortcircuit-proof and incorporates a temperature protection which turns off the IC at overtemperature.

## Choosing External Components

The input capacitor  $C_I$  is necessary for compensating line influences. Using a resistor of approx. 1  $\Omega$  in series with  $C_I$ , the oscillating of input line inductivity and input capacitance can be clamped. The output capacitor  $C_Q$  is necessary for the stability of the regulating circuit. Stability is guaranteed at values  $C_Q \geq 10$   $\mu$ F and an ESR  $\leq 10$   $\Omega$  within the whole operating temperature range.

Type	Ordering Code	Package
TLE 4266 G	Q67006-A9152	P-SOT223-4-2
TLE 4266 GSV10	Q67006-A9355	P-SOT223-4-2



**Figure 1** Pin Configuration (top view)

**Table 1** Pin Definitions and Functions

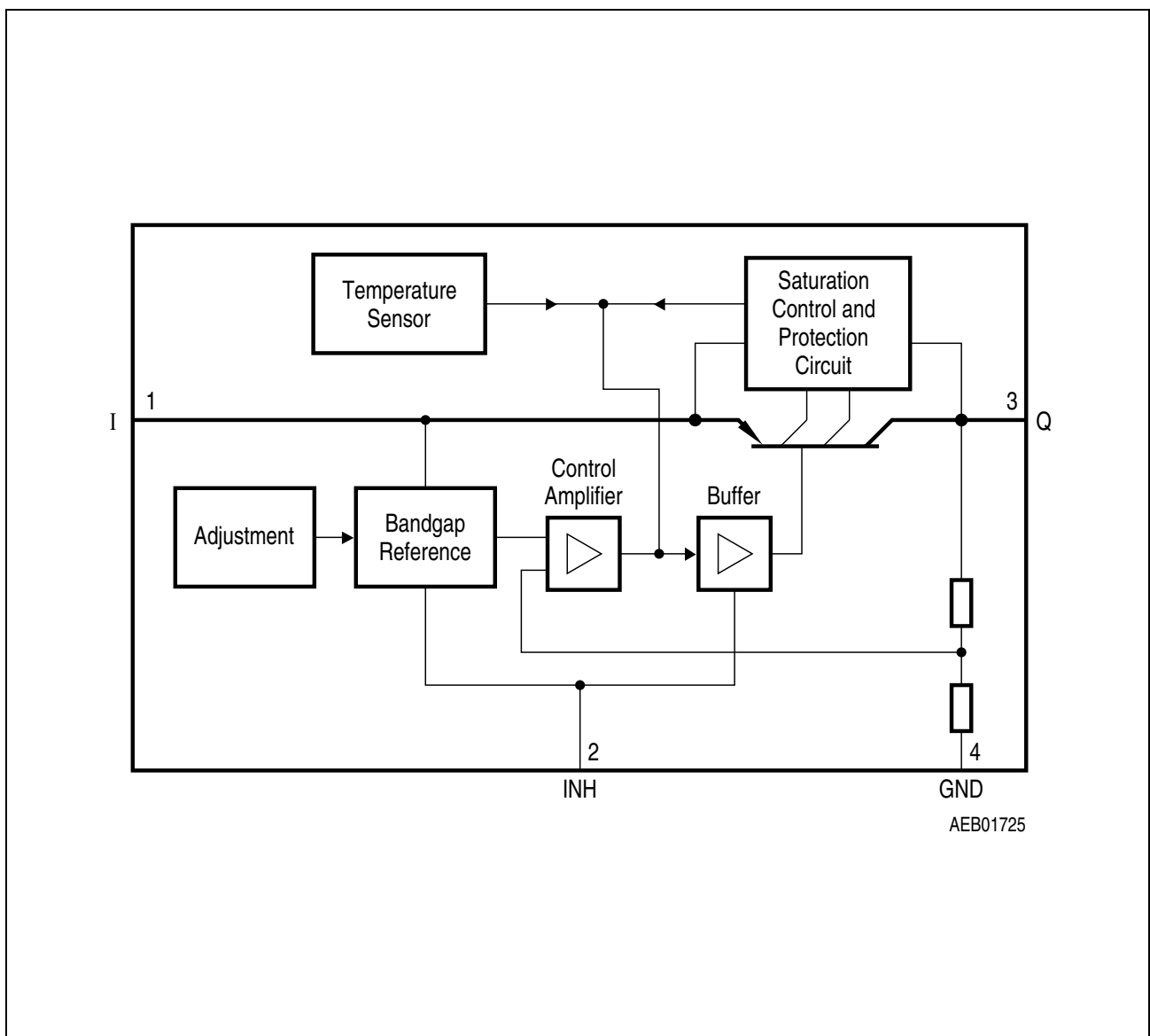
Pin	Symbol	Function
1	I	<b>Input voltage</b> ; block to ground directly at the IC with a ceramic capacitor.
2	INH	<b>Inhibit</b> ; low-active input.
3	Q	<b>Output voltage</b> ; block to ground with a capacitor $C_Q \geq 10 \mu\text{F}$ .
4	GND	<b>Ground</b>

### Circuit Description

The device includes a precise reference voltage, which is very accurate due to resistor adjustment. A control amplifier compares the divided output voltage to this reference voltage and drives the base of the PNP series transistor through a buffer.

Saturation control as a function of the load current prevents any oversaturation of the power element. The IC also incorporates a number of protection circuitry for:

- Overload
- Overtemperature
- Reverse polarity



**Figure 2 Block Diagram**

**Table 2 Absolute Maximum Ratings (TLE 4266 G, TLE 4266 GSV10)**
 $T_j = -40$  to  $150$  °C

Parameter	Symbol	Limit Values		Unit	Notes
		Min.	Max.		
<b>Input</b>					
Voltage	$V_I$	-42	45	V	–
Current	$I_I$	–	–	–	internally limited
<b>Inhibit</b>					
Voltage	$V_{INH}$	-42	45	V	–
<b>Output</b>					
Voltage	$V_Q$	-1	32	V	–
Current	$I_Q$	–	–	–	internally limited
<b>GND</b>					
Current	$I_{GND}$	50	–	mA	–
<b>Temperature</b>					
Junction temperature	$T_j$	–	150	°C	–
Storage temperature	$T_S$	-50	150	°C	–
<b>Operating Range (TLE 4266 G)</b>					
Input voltage	$V_I$	5.5	45	V	–
Junction temperature	$T_j$	-40	150	°C	–
<b>Operating Range (TLE 4266 GSV10)</b>					
Input voltage	$V_I$	10.5	45	V	–
Junction temperature	$T_j$	-40	150	°C	–
<b>Thermal Resistance</b>					
Junction ambient	$R_{thj-a}$	–	165	K/W	<sup>1)</sup>
Junction case	$R_{thj-pin}$	–	17	K/W	measured to pin 4

<sup>1)</sup> Package mounted on PCB  $80 \times 80 \times 1.5$  mm<sup>3</sup>; 35μ Cu; 5μ Sn; Footprint only; zero airflow.

**Table 3 Characteristics (TLE 4266 G)**
 $V_i = 13.5 \text{ V}; -40 \text{ }^\circ\text{C} \leq T_j \leq 125 \text{ }^\circ\text{C}$ 

Parameter	Symbol	Limit Values			Unit	Test Condition
		Min.	Typ.	Max.		
Output voltage	$V_Q$	4.9	5	5.1	V	$5 \text{ mA} \leq I_Q \leq 100 \text{ mA}$ $6 \text{ V} \leq V_i \leq 28 \text{ V}$
Output-current limitation	$I_Q$	120	150	–	mA	–
Current consumption $I_q = I_i - I_Q$	$I_q$	–	–	10	$\mu\text{A}$	$V_{\text{INH}} = 0 \text{ V};$ $T_j \leq 100 \text{ }^\circ\text{C}$
Current consumption $I_q = I_i - I_Q$	$I_q$	–	–	400	$\mu\text{A}$	$I_Q = 1 \text{ mA}$ Inhibit ON
Current consumption $I_q = I_i - I_Q$	$I_q$	–	10	15	mA	$I_Q = 100 \text{ mA}$ Inhibit ON
Drop voltage	$V_{\text{DR}}$	–	0.25	0.5	V	$I_Q = 100 \text{ mA}^{1)}$
Load regulation	$\Delta V_{Q,\text{lo}}$	–	–	40	mV	$I_Q = 5 \text{ to } 100 \text{ mA}$ $V_i = 6 \text{ V}$
Line regulation	$\Delta V_{Q,\text{li}}$	–	15	30	mV	$V_i = 6 \text{ V to } 28 \text{ V}$ $I_Q = 5 \text{ mA}$
Power supply ripple rejection	$PSRR$	–	54	–	dB	$f_r = 100 \text{ Hz},$ $V_r = 0.5 \text{ Vpp}$

**Inhibit**

Inhibit on voltage	$V_{\text{INH, on}}$	3.5	–	–	V	–
Inhibit off voltage	$V_{\text{INH, off}}$	–	–	0.8	V	–
Inhibit current	$I_{\text{INH}}$	5	15	25	$\mu\text{A}$	$V_{\text{INH}} = 5 \text{ V}$

1) Drop voltage =  $V_i - V_Q$  (measured when the output voltage  $V_Q$  has dropped 100 mV from the nominal value obtained at  $V_i = 13.5 \text{ V}$ ).

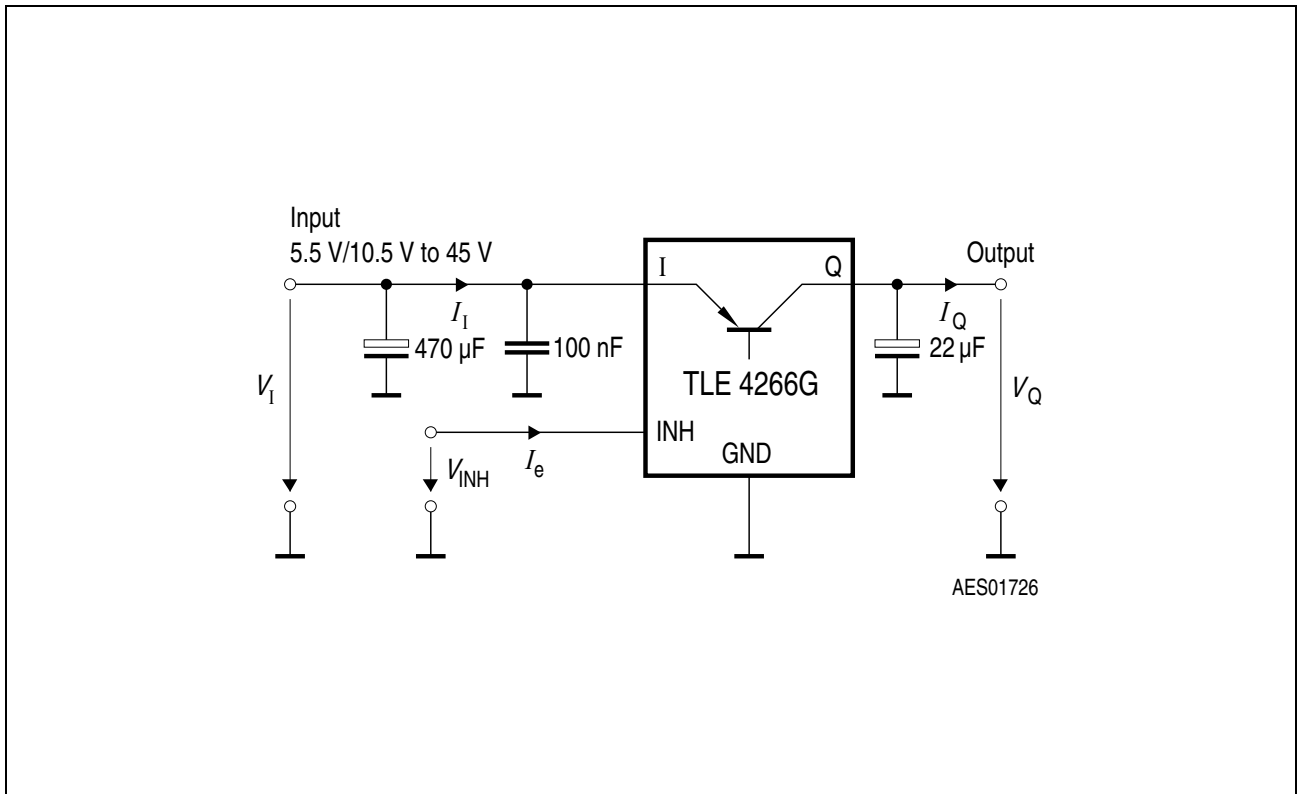
**Table 4 Characteristics (TLE 4266 GSV10)**
 $V_I = 13.5 \text{ V}; -40 \text{ }^\circ\text{C} \leq T_j \leq 125 \text{ }^\circ\text{C}$ 

Parameter	Symbol	Limit Values			Unit	Test Condition
		Min.	Typ.	Max.		
Output voltage	$V_Q$	9.8	10	10.2	V	$5 \text{ mA} \leq I_Q \leq 100 \text{ mA}$ $11 \text{ V} \leq V_I \leq 21 \text{ V}$
Output voltage	$V_Q$	9.8	10	10.2	V	$1 \text{ mA} \leq I_Q \leq 50 \text{ mA}$ $11 \text{ V} \leq V_I \leq 28 \text{ V}$
Output-current limitation	$I_Q$	120	150	200	mA	–
Current consumption $I_q = I_I - I_Q$	$I_{q,off}$	–	–	10	$\mu\text{A}$	$V_{INH} = 0 \text{ V};$ $T_j \leq 100 \text{ }^\circ\text{C}$
Current consumption $I_q = I_I - I_Q$	$I_q$	–	350	500	$\mu\text{A}$	$I_Q < 1 \text{ mA}$ Inhibit ON
Current consumption $I_q = I_I - I_Q$	$I_q$	–	7	15	mA	$I_Q < 100 \text{ mA}$ Inhibit ON
Drop voltage	$V_{DR}$	–	0.28	0.5	V	$I_Q = 100 \text{ mA}^{1)}$
Load regulation	$\Delta V_{Q,Lo}$	-80	–	80	mV	$I_Q = 5 \text{ to } 100 \text{ mA}$ $V_I = 11 \text{ V}$
Line regulation	$\Delta V_{Q,Li}$	-30	5	30	mV	$V_I = 11 \text{ V to } 28 \text{ V}$ $I_Q = 5 \text{ mA}$
Power supply ripple rejection	$PSRR$	–	54	–	dB	$f_r = 100 \text{ Hz},$ $V_r = 0.5 \text{ Vpp}$

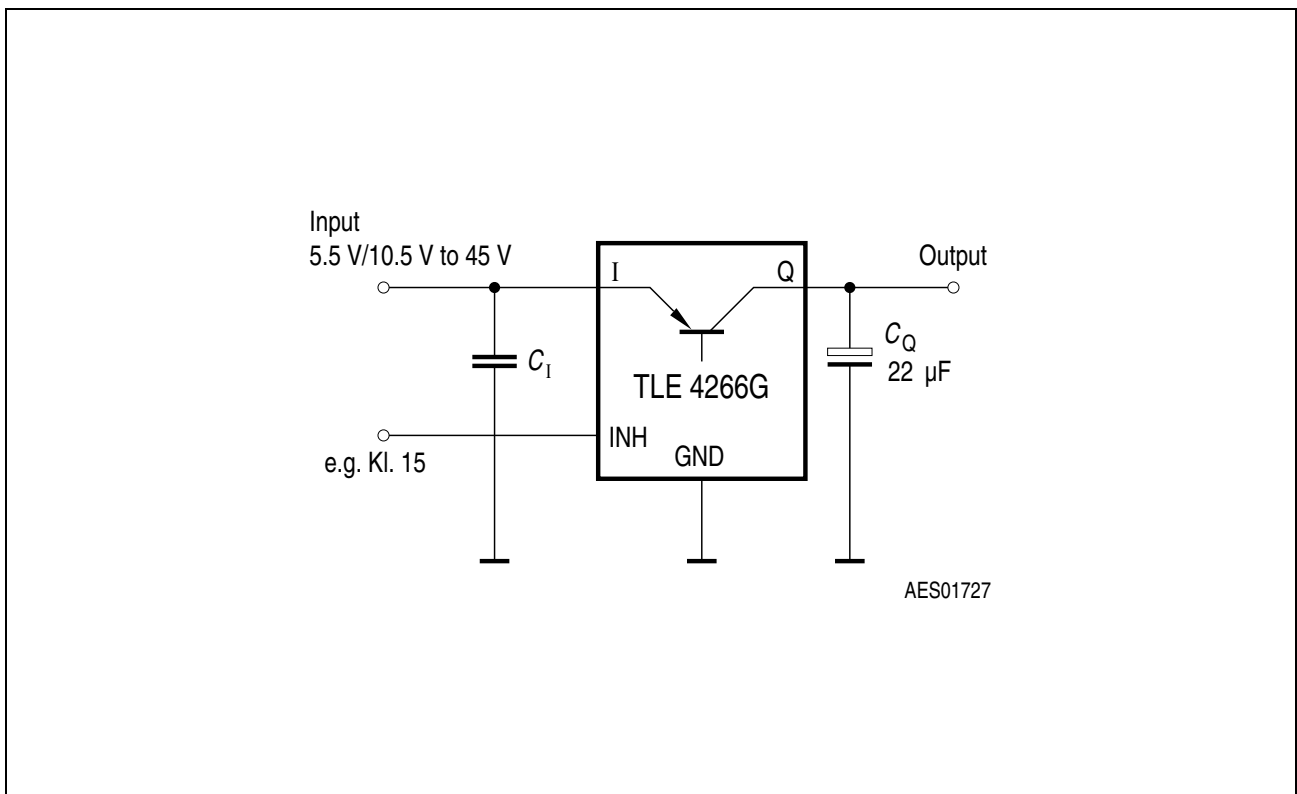
**Inhibit**

Inhibit on voltage	$V_{INH, on}$	3.5	–	–	V	–
Inhibit off voltage	$V_{INH, off}$	–	–	0.8	V	–
Inhibit current	$I_{INH}$	5	12	25	$\mu\text{A}$	$V_{INH} = 5 \text{ V}$

1) Drop voltage =  $V_I - V_Q$  measured when the output voltage  $V_Q$  has dropped 100 mV from the nominal value.

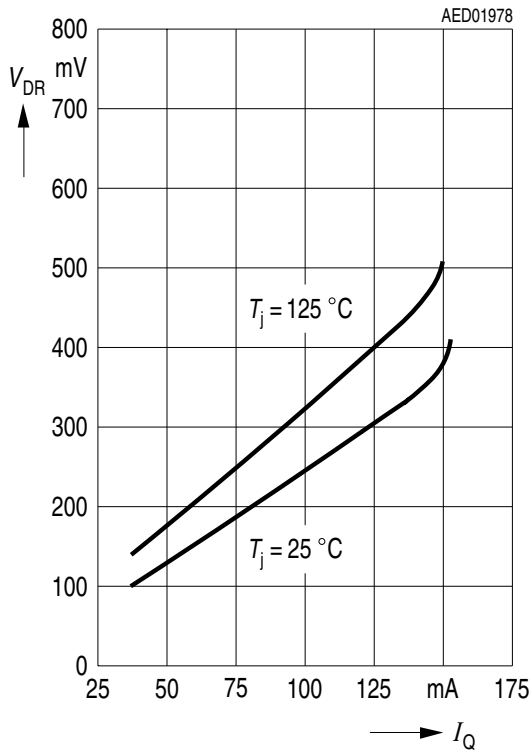


**Figure 3 Measuring Circuit (TLE 4266 G, TLE 4266 GSV10)**

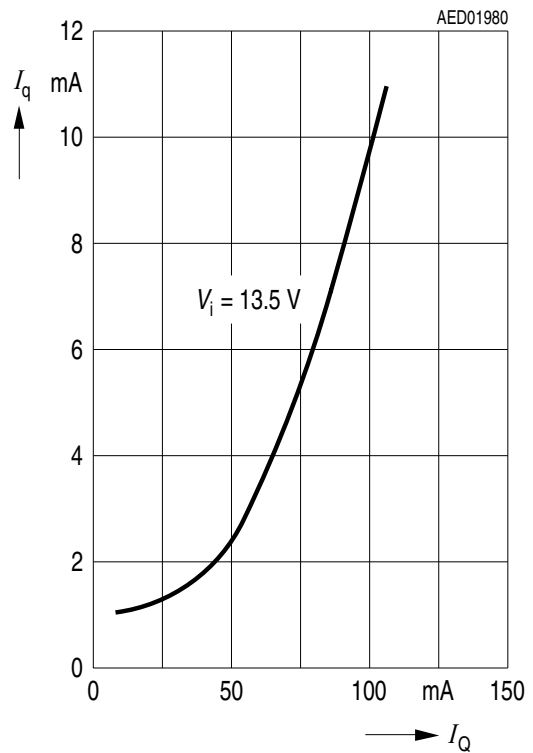


**Figure 4 Application Circuit (TLE 4266 G, TLE 4266 GSV10)**

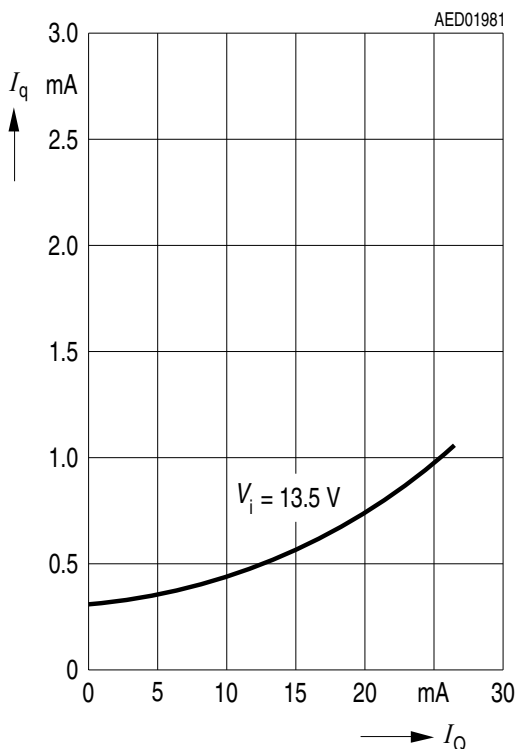
**Drop Voltage  $V_{DR}$  versus Output Current  $I_Q$  (5 V, 10 V)**



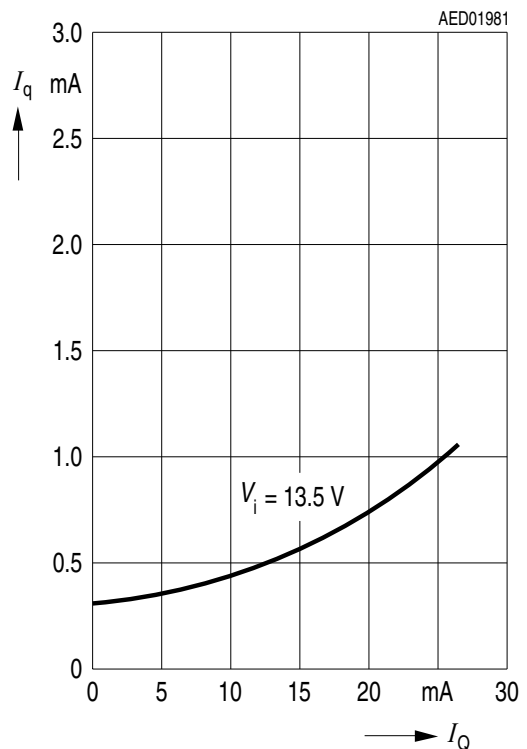
**Current Consumption  $I_q$  versus Output Current  $I_Q$  (5 V)**



**Current Consumption  $I_q$  versus Output Current  $I_Q$  (5 V version)**

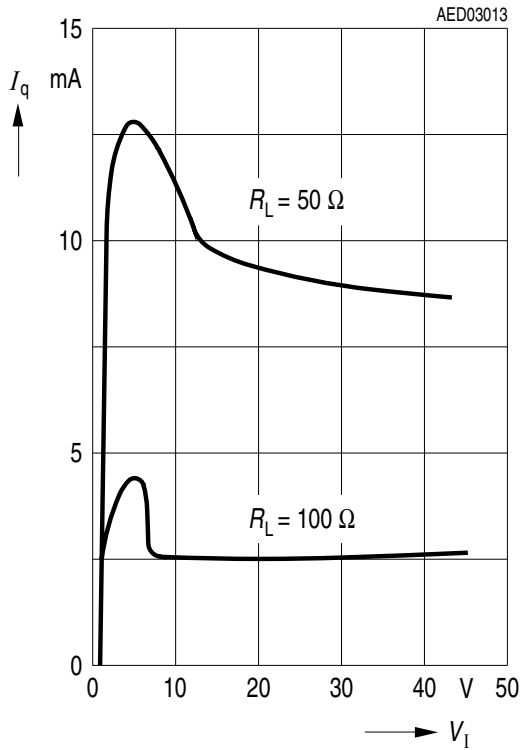


**Current Consumption  $I_q$  versus Output Current  $I_Q$  (10 V version)**

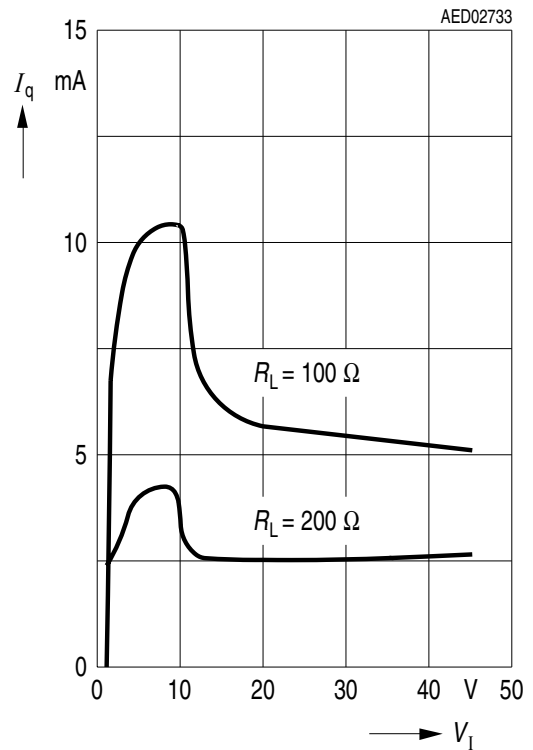




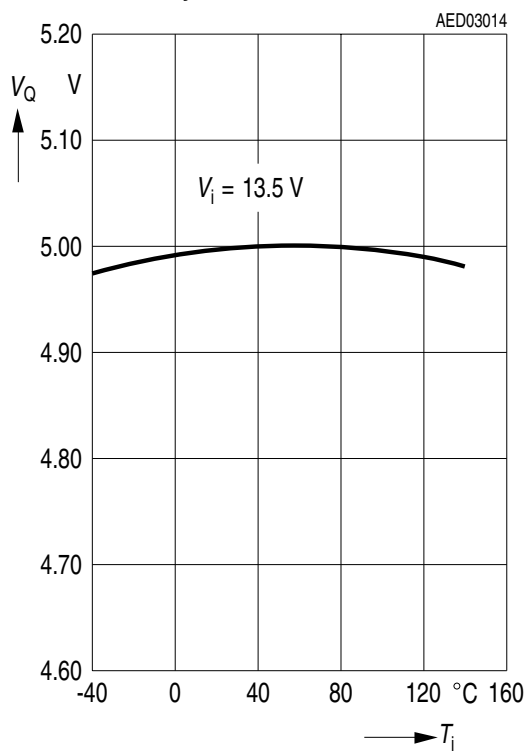
**Current Consumption  $I_q$  versus Input Voltage  $V_i$  (5 V version)**



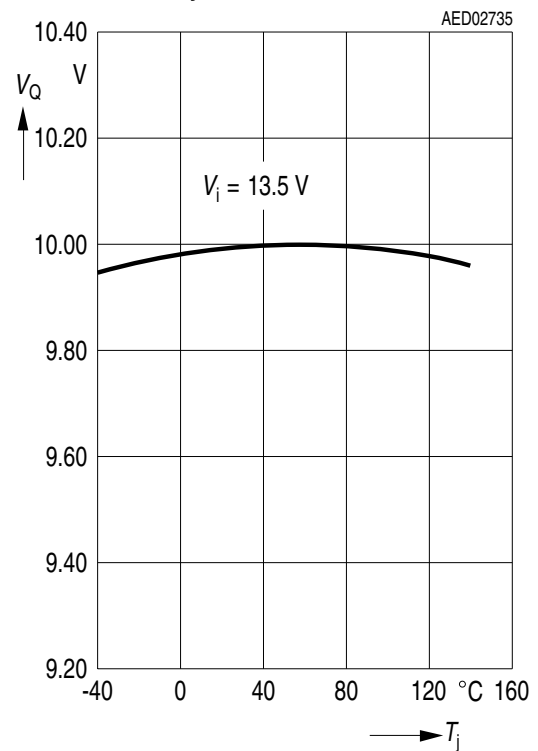
**Current Consumption  $I_q$  versus Input Voltage  $V_i$  (10 V version)**



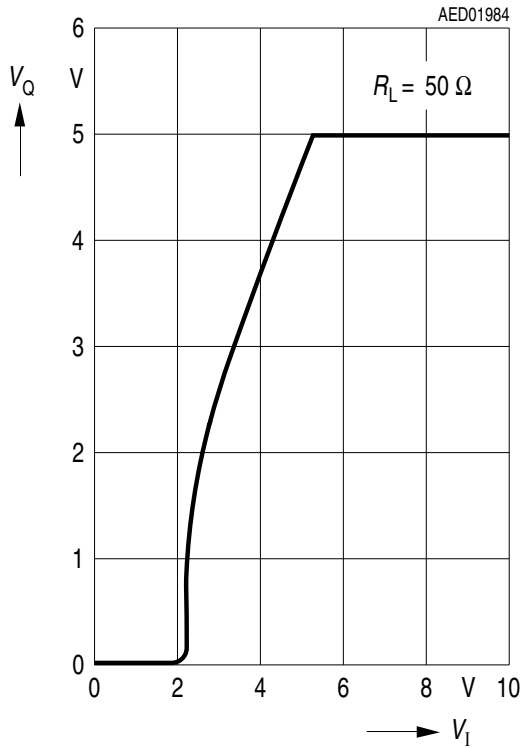
**Output Voltage  $V_Q$  versus Temperature  $T_j$  (5 V version)**



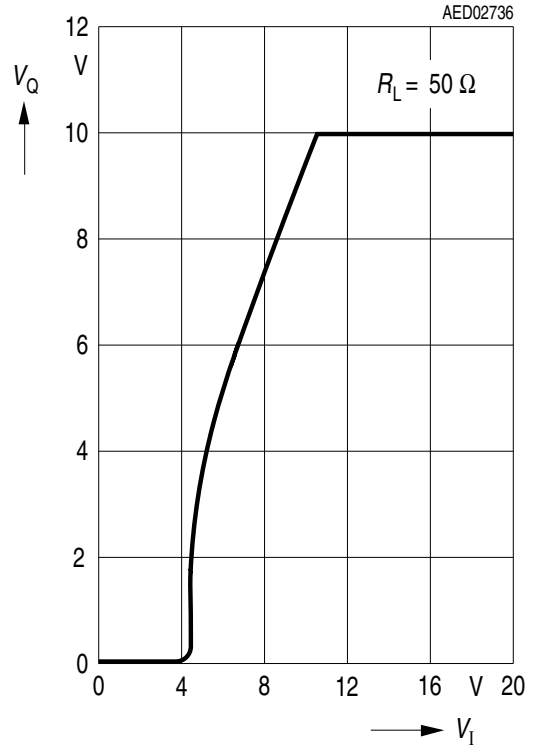
**Output Voltage  $V_Q$  versus Temperature  $T_j$  (10 V version)**



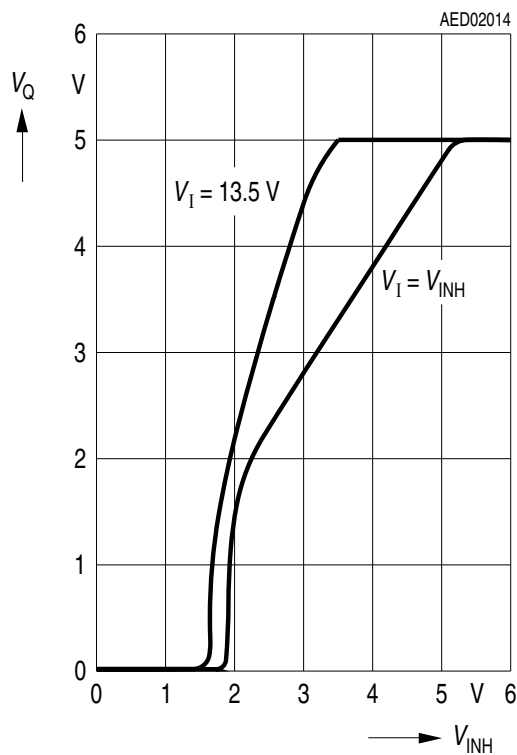
**Output Voltage  $V_Q$  versus Input Voltage  $V_I$  (5 V version)**



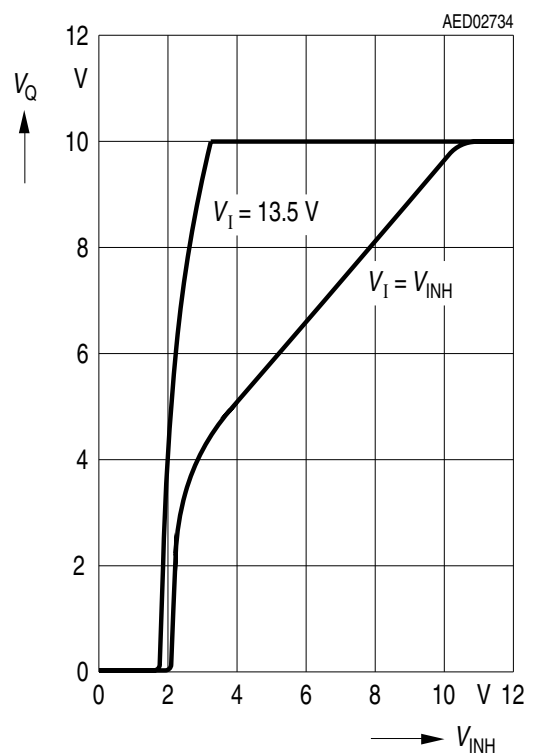
**Output Voltage  $V_Q$  versus Input Voltage  $V_I$  (10 V version)**



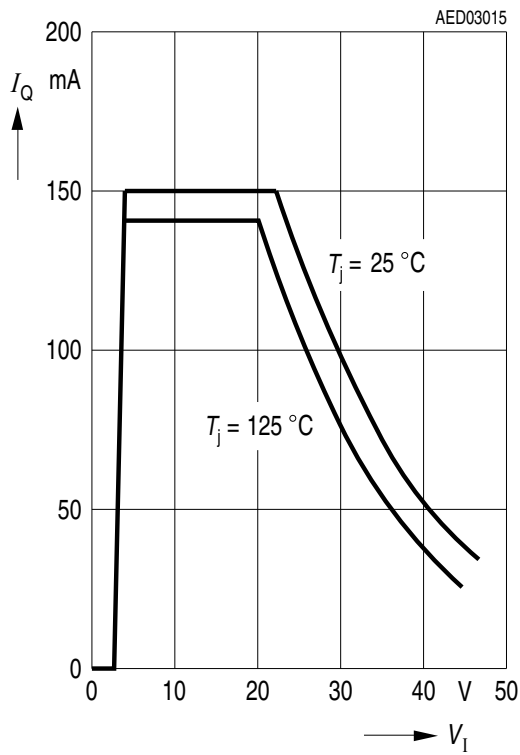
**Output Voltage  $V_Q$  versus Inhibit Voltage  $V_{INH}$  (5 V version)**



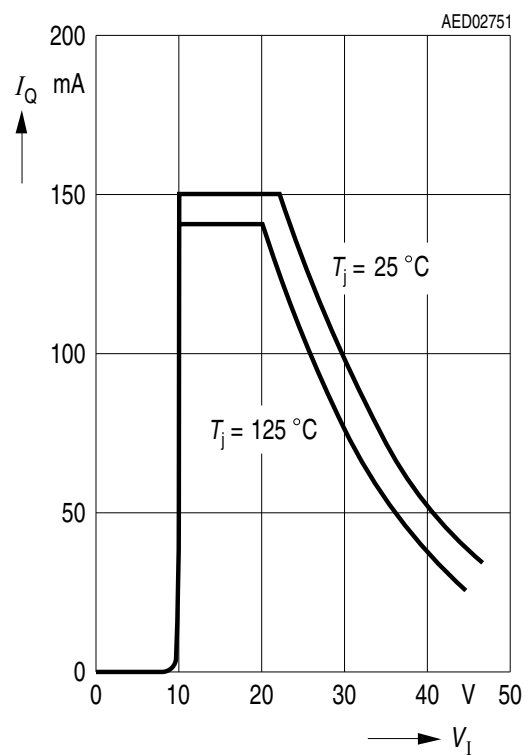
**Output Voltage  $V_Q$  versus Inhibit Voltage  $V_{INH}$  (10 V version)**



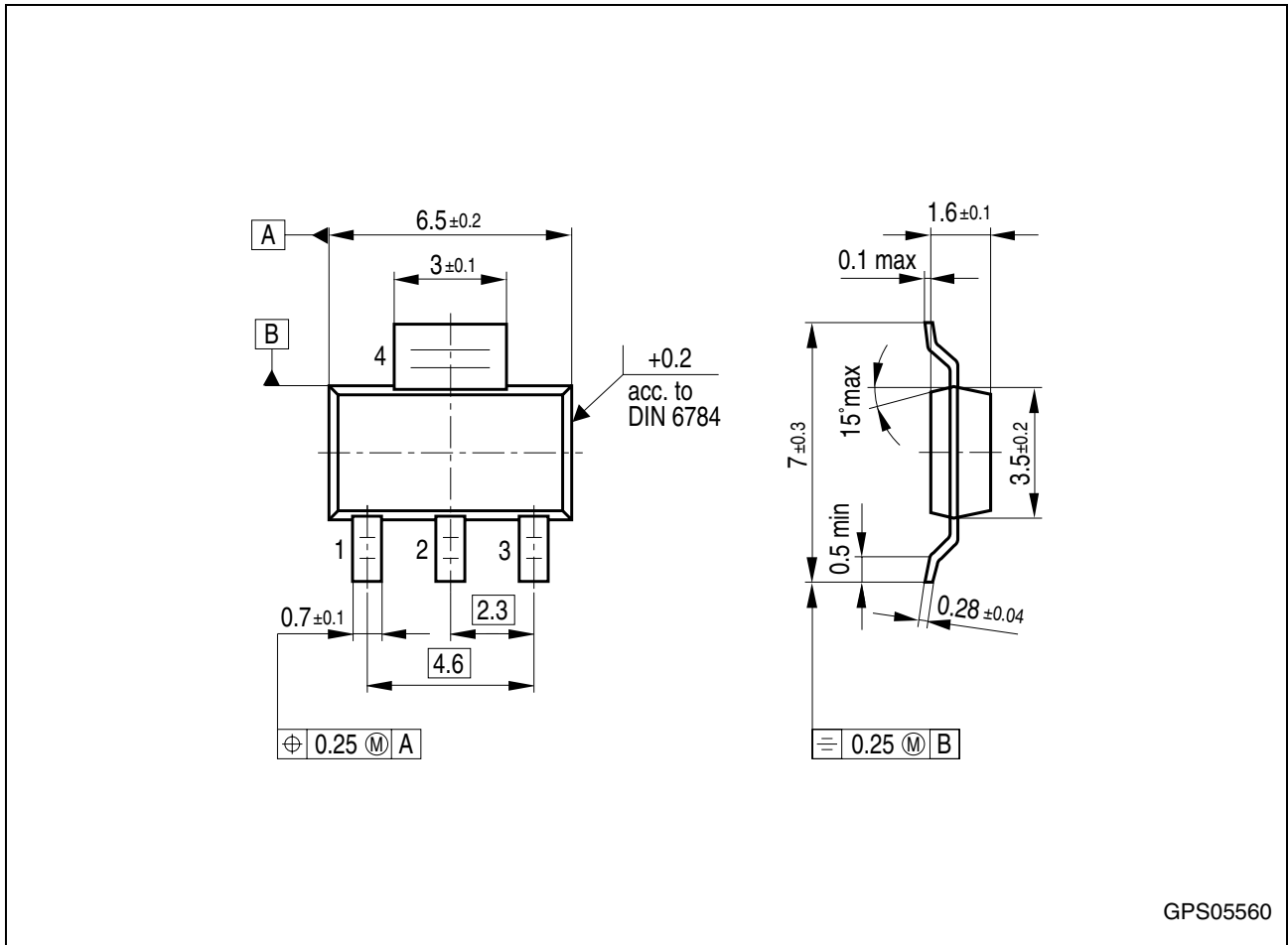
**Output Current  $I_Q$  versus Input Voltage  $V_I$  (5 V-version)**



**Output Current  $I_Q$  versus Input Voltage  $V_I$  (10 V version)**



Package Outlines



GPS05560

Figure 5 P-SOT223-4-2 (Plastic Small Outline Transistor)

You can find all of our packages, sorts of packing and others in our Infineon Internet Page "Products": <http://www.infineon.com/products>.

SMD = Surface Mounted Device

Dimensions in mm

**Edition 2004-01-01**

**Published by Infineon Technologies AG,  
St.-Martin-Strasse 53,  
81669 München, Germany**

**© Infineon Technologies AG 2004.  
All Rights Reserved.**

**Attention please!**

The information herein is given to describe certain components and shall not be considered as a guarantee of characteristics.

Terms of delivery and rights to technical change reserved.

We hereby disclaim any and all warranties, including but not limited to warranties of non-infringement, regarding circuits, descriptions and charts stated herein.

**Information**

For further information on technology, delivery terms and conditions and prices please contact your nearest Infineon Technologies Office ([www.infineon.com](http://www.infineon.com)).

**Warnings**

Due to technical requirements components may contain dangerous substances. For information on the types in question please contact your nearest Infineon Technologies Office.

Infineon Technologies Components may only be used in life-support devices or systems with the express written approval of Infineon Technologies, if a failure of such components can reasonably be expected to cause the failure of that life-support device or system, or to affect the safety or effectiveness of that device or system. Life support devices or systems are intended to be implanted in the human body, or to support and/or maintain and sustain and/or protect human life. If they fail, it is reasonable to assume that the health of the user or other persons may be endangered.